

- 1
- 2
- 3
- 4
- 5
- 6
- 7
- 8
- 9
- 10
- 11
- 12
- 13
- 14
- 15
- 16
- 17
- 18

MATERIAL

Die-cast zinc alloy, epoxy resin coating, RAL 9005 black colour, matte finish.

STANDARD EXECUTIONS

Revolving handle in polyamide based (PA) technopolymer, black colour, matte finish.

- GN 471.1-B: H7 reamed hole.
- GN 471.1-V: H11 square hole.

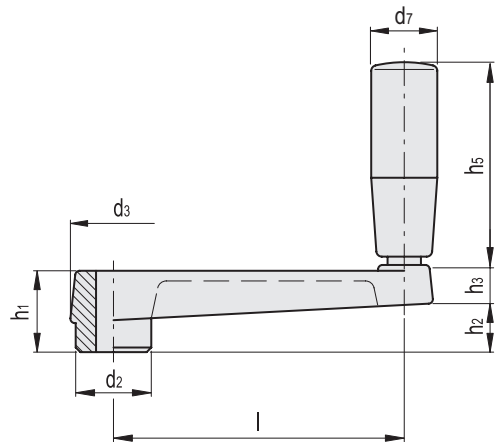
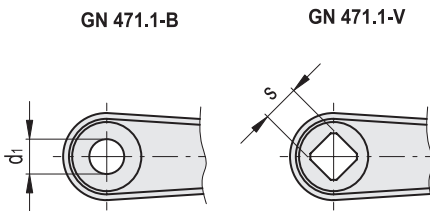

Conversion Table	
1 mm = 0,039 inch	
mm	inch
64	2.52

GN 471.1-B

Code	Description	l	d1 H7	d2	d3	h1	h2	h3	h5	d7	⚖
GN.22501	GN 471.1-64-B10	64	B 10	19	22	20	11	12	42.5	18	100

GN 471.1-V

Code	Description	l	sH11	d2	d3	h1	h2	h3	h5	d7	⚖
GN.22502	GN 471.1-64-V10	64	10	19	22	20	11	12	42.5	18	95